

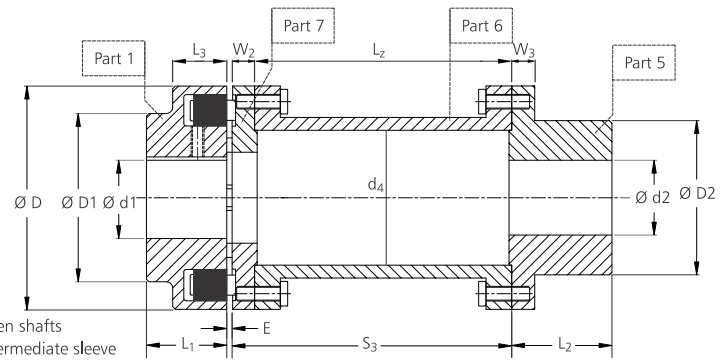

UTL FLEXIBLE COUPLINGS

**Utkarsh**  
FLEXIBLE COUPLINGS  
Revolutionizing Rotation

UTL UNS TYPE H COUPLINGS

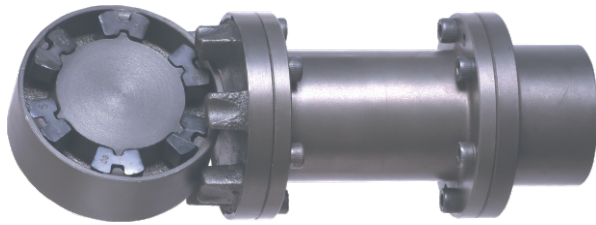

S<sub>3</sub> - Space between shafts  
L<sub>2</sub> - Length of intermediate sleeve

**FEATURES**

- Coupling made of cast iron GG 25
- Torsionally flexible, maintenance free, vibration-damping
- Axial plug-in, fail-safe
- Finish bore according to ISO fit, feather keyway according to DIN 6885 sheet 1 - JS9 and P9

**DIMENSIONS & TECHNICAL DATA**

Size H	Rated Torque Nm	Max. Torque Nm	Max. Speed rpm	Pilot Bore mm	Max. Bore		Dimensions are in mm													Weight in Kg	Moment of inertia (kg.m <sup>2</sup> )
					Ød1mm	Ød2mm	Ød4mm	ØD	ØD1	ØD2	L <sub>2</sub> *	L <sub>1</sub>	L <sub>2</sub>	L <sub>3</sub>	S <sub>3</sub>	W <sub>2</sub>	W <sub>3</sub>	E			
80	60	180	5000	-	30	32	51	80	-	55	87	30	45	30	100	10	9	5-7	On request UTL will provide data.	On request UTL will provide data. According to spacer length.	
95	100	300	5000	-	42	42	63	95	75	70	87	35	45	30	100	10	9	5-7			
110	160	480	5000	-	48	48	73	110	86	80	125	40	50	34	140	12	11	5-7			
125	240	720	5000	-	55	55	85	125	100	90	125	50	60	36	140	12	11	5-7			
140	360	1080	4900	-	60	60	91	140	100	100	162	55	65	34	180	15	15	5-7			
160	560	1680	4250	-	65	65	111	160	108	108	182	60	70	39	200	15	15	6-8			
180	880	2640	3800	-	75	75	131	180	125	125	182	70	80	42	200	15	15	6-8			
200	1340	4020	3400	-	85	85	144	200	140	140	228	80	90	47	250	18	18	6-8			
225	2000	6000	3000	-	90	90	160	225	150	150	228	90	100	52	250	18	18	6-8			
250	2800	8400	2750	44	100	100	185	250	165	165	222	100	110	60	250	23	21	8-10			

- L<sub>2</sub>\* = Standard dimensions, for other dimensions, please specify when ordering
- Permissible temperature range of ambient air and machine shaft ends between -30°C and +80°C

**MATERIAL SPECIFICATIONS**

Hub	Size -80 - 250	Cast Iron	CI	DIN 1693 GG 25
Spacer	Size -80 - 250	Cast Iron	CI	DIN 1693 GG 25
H cushion 80° shore A	Size -80 - 250	Nitrile Rubber	NBR	ASTM D2000 BG 810

- Alternative for higher power ratings

H cushion 92° shore A	Size -80 - 250	Nitrile Rubber	NBR	ASTM D2000 BG 910
-----------------------	----------------	----------------	-----	-------------------

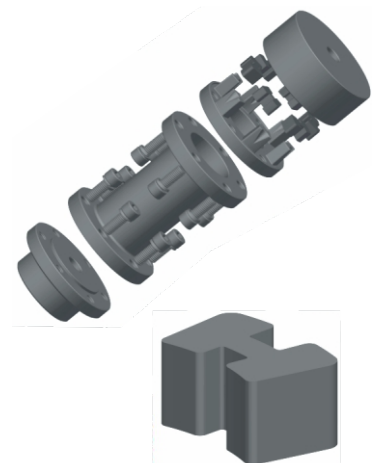

\* For temperature range of elastomers please see on page no. 47 - coupling selection  
www.utlcoupling.com